

**Präzisionskurzbohrfutter für Links-und Rechtslauf**

**Mandrins de précision courts tourn. à g. et à dr.**

**NC - drill chucks for left and right rotation**

**681820..**

- Kurze, stabile Ausführung
- Hohe Spannkraft durch Getriebeübersetzung, Spannschlüssel inkl.
- Einfache und schnelle Bedienung über Sechskant-Stiftschlüssel System WTE
- Verzugsarm gehärtet, Oberflächenhärte HRC 60±2, Härtetiefe 0.8mm ±0.2 mm
- Maximaler Rundlauffehler < 0.003mm, Oberflächenrauigkeit < 0,5 μ

- *Exécution courte et robuste*
- *Haute force de serrage grâce à la multiplication par engrenage, clef inclus*
- *Opération simple et rapide à l'aide de la clé mâle 6 pans, système WTE*
- *Trempé sans deviation de forme à HRC 60±2, prof. de trempe 0.8mm ±0.2 mm*
- *concentricité max < 0.003 mm, rugosité < 0,5 μ*

- Short and stable execution
- High clamping force by means of a gear translation, key inclusive
- Simple and rapid operation by a hexagonal insert key system WTE
- Distortion-low hardened, surface, hardness HRC 60±2, depth 0.8mm ±0.2 mm
- Maximal runn-out error <0.003mm, surface roughness < 0,5 μ



**DIN69871 AD**

Steilkegel cône taper DIN 69871	Spannbereich capacité clamp. Range [mm]			A	D	Best. Nr. no.cde order no.	CHF
						6.81820111	
30	0	-	8	70	36	681820. 005	498.00
30	1	-	13	111	50	681820. 010	446.00
30	2.5	-	16	116	50	681820. 015	446.00
40	0	-	8	70	36	681820. 018	371.00
40	1	-	13	90	50	681820. 030	371.00
40	2.5	-	16	95	50	681820. 050	593.00
50	1	-	13	90	50	681820. 070	668.00
50	2.5	-	16	95	50	681820. 090	698.00

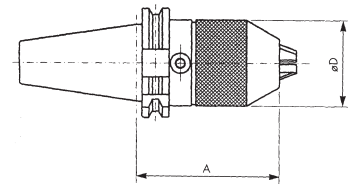

Steilkegel cône taper MAS 403 BT	Spannbereich capacité clamping range [mm]			A	D	Best. Nr. no.cde order no.	CHF
						6.81820BT111	
30	0.5	-	8	73	36	681830. 005	498.00
30	1	-	13	93	50	681830. 010	446.00
30	2.5	-	16	98	50	681830. 015	446.00
40	0	-	8	78	36	681830. 018	398.00
40	1	-	13	98	50	681830. 030	298.00
40	2.5	-	16	103	57	681830. 045	329.00
50	1	-	13	111	50	681830. 070	384.00
50	2.5	-	16	113	50	681830. 090	411.00

**681830..  
MAS/BT**

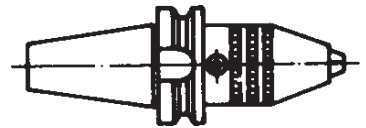

Steilkegel cône taper DIN 2080	Spannbereich capacité clamping range [mm]			A	D	Best. Nr. no.cde order no.	CHF
						6.81840111	
30	0	-	8	60	36	681840. 005	493.00
30	0	-	13	90	50	681840. 010	493.00
30	2.5	-	16	95	50	681840. 015	493.00
40	0	-	8	63	36	681840. 020	387.00
40	1	-	13	83	50	681840. 030	344.00
40	2.5	-	16	88	50	681840. 040	366.00
50	1	-	13	85	50	681840. 060	399.00
50	2.5	-	16	90	50	681840. 080	427.00

**681840..  
DIN 2080**

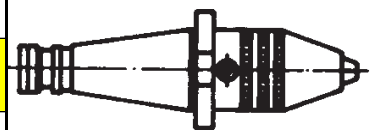

Ausführungen ANSI/CAT und Chiron/Stama auf Anfrage/ Executions from ANSI CAT / Chiron/Stama on request/Executions AINSI/CAT/Chiron/Stama s.demande

**Anzugsbolzen DIN 69872 Form A und B**

**Tirettes DIN 69872 forme A et B**

**Pull studs according DIN 69872 forme A & B**

**681824..**

Form A 

Steilkegel cône taper DIN 69871	Best Nr. No.cde order no.										CHF
30	13	9	17	13	M12	44	24	19	13	681824. 020	26.90
40	19	14	23	17	M16	54	26	20	21	681824. 040	14.85
45	23	17	30	21	M20	65	30	23	27	681824. 060	35.10
50	28	21	36	25	M24	74	34	25	30	681824. 080	19.80

Passender O-Ring bague -O O-ring	Best Nr. No. cde. order no.	CHF
		6.81824111
11 x 1.0	681825. 020	*
14 x 1.5	681825. 040	14.80
17 x 2.0	681825. 060	35.10
20 x 2.5	681825. 080	32.20

**681825..**

Form B 

\* auf Anfrage / sur demande / on request

**Fräseraufnahmen DIN 6359 für Zylinderschäfte DIN 1835 B, Weldon** **Porte - fraises DIN 6359 pour queue cylindriques 1835- B Weldon** **End mill holders DIN 6359 for end mills DIN 1835 B, Weldon**

- Stabil, präzisiongeschliffen,
  - Verzugsarm gehärtet, HRC 60±2, Härtetiefe 0.8mm ±0.2 mm
  - Oberflächenrauigkeit < 0,5 µ
  - Qualität besser als Norm DIN 69871
- Bohrungstoleranz H4, max. Rundlaufabweichung kleiner 0.005mm

- Robuste, rectifiée à haute précision
- Trempé sans deviation de forme à HRC 60±2, prof. de trempe 0.8mm ±0.2 mm
- rugosité < 0,5 µ
- Qualité meilleure que DIN 69871, tolérance du perçage H4, concentricité moins de 0.005mm

- Stabile execution, precision ground,
- distortion-low hardened, HRC 60±2, hardness depth 0.8mm ±0.2 mm
- surface roughness < 0,5 µ
- quality superior than DIN 69871, bore tolerance H4, maximal run-out deviation < 0.005mm

**663005..**  
**DIN 69871**  
Form AD

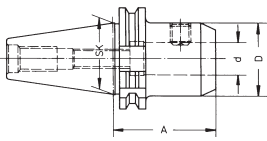

**663010..**  
**DIN 69871**  
Form AD/B

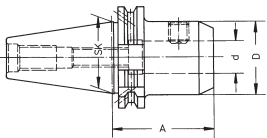

Steilkegel cône taper DIN 69871	Spannbereich capacité clamping range d [mm]	A	Best. Nr. n o.cde order no. Form AD	6.63005111 CHF
30	6	50	663005. 002	68.00
30	8	50	663005. 004	64.00
30	10	50	663005. 006	64.00
30	12	50	663005. 008	64.00
30	14	63	663005. 010	64.00
30	16	63	663005. 012	64.00
30	18	63	663005. 014	64.00
30	20	70	663005. 016	64.00
<b>Form AD/B</b>				
40	6	50	663010. 020	96.00
40	6	100	663010. 022	82.00
40	6	160		
40	8	50	663010. 026	96.00
40	8	100	663010. 028	76.00
40	8	160		
40	10	50	663010. 032	89.00
40	10	100	663010. 034	76.00
40	10	160		
40	12	50	663010. 038	89.00
40	12	100	663010. 040	89.00
40	12	160		
40	14	50	663010. 044	89.00
40	14	100	663010. 046	89.00
40	14	160		
40	16	63	663010. 050	89.00
40	16	100	663010. 054	89.00
40	16	160		
40	18	63	663010. 056	89.00
40	18	100		
40	18	160		
40	20	63	663010. 062	89.00
40	20	100	663010. 066	89.00
40	20	160	663010. 068	98.00
40	25	35		
40	25	100	663010. 070	79.50
40	25	160	663010. 072	165.00
40	32	65		
40	32	100	663010. 074	112.00
40	32	160	663010. 075	211.50
40	40	120	663010. 076	0.00
50	6	63	663010. 102	120.00
50	6	100		
50	6	160		
50	8	63	663010. 108	115.00
50	8	100		
50	8	160		
50	10	63	663010. 114	115.00
50	10	100		
50	10	160		
50	12	63	663010. 120	115.00
50	12	100		
50	12	160		
50	14	63	663010. 126	115.00
50	14	100		
50	14	160		
50	16	63	663010. 132	115.00
50	16	100		
50	16	160		
50	18	63	663010. 138	115.00
50	18	100		
50	18	160		
50	20	63	663010. 144	115.00
50	20	100		
50	20	160		
50	22	63	663010. 150	118.00
50	25	80	663010. 152	130.00
50	25	120		
50	25	160		
50	32	100	663010. 156	138.00
50	32	160		
50	40	100	663010. 160	173.00
50	40	160		

**Fräseraufnahmen DIN 6359 für Zylinderschäfte DIN 1835-B Weldon**

**Porte fraises DIN 6359 p. queues cylindriques DIN 1835-B Weldon**

**Endmill holders DIN 6359 for cylindrical shanks DIN 1835-B Weldon**

**663015..  
663017..  
MAS/BT  
AD & AD/B**

Steilkegel cône taper BT/DIN	Spannbereich apacité clamping range d [mm]	MAS/BT			DIN 2080		
		A	Best. Nr./no.cde. order no. Norm AD/B	Fr.	A	Best. Nr. order no no.cde	Fr.
30	6	50	663015.002	72.00	40	663018 002	79.20
30	8	50	663015.004	65.00	40	663018 004	73.20
30	10	50	663015.006	65.00	40	663018 006	73.20
30	12	50	663015.008	65.00	40	663018 008	73.20
30	14	50	663015.012	65.00	50	663018 012	
30	16	63	663015.014	65.00	50	663018 014	73.20
30	18	63	663015.016	65.00	50	663018 016	
30	20	63	663015.018	65.00	63	663018 018	
40	6	50	663015.020	84.00	50	663018 020	84.00
40	6	100			50		
40	8	50	663015.026	84.00	50	663018 026	84.00
40	8	100			50		
40	10	63	663015.032	84.00	50	663018 032	84.00
40	10	100			50		
40	12	63	663015.038	84.00	50	663018 038	84.00
40	12	100			50		
40	14	63					
40	14	100					
40	16	35					
40	16	63	663015.050	84.00	63	663018 050	84.00
40	16	100					
40	18	63			63	663018 054	84.00
40	18	100					
40	20	35					
40	20	63	663015.062	84.00	63	663018 062	84.00
40	20	100					
40	25	35			80		
40	25	90	663015.070	93.00	80	663018 070	93.00
40	32	65					
40	32	100	663015.074	101.00	80	663018 074	0.00
40	40	120			90	663018 078	
50	6	63	663015.102	122.00	63	663018 102	122.00
50	8	63	663015.108	122.00	63	663018 108	122.00
50	10	63	663015.114	122.00	63	663018 114	122.00
50	12	80	663015.120	122.00	63	663018 120	122.00
50	14	80			63	663018 120	
50	16	80	663015.132	122.00	63	663018 132	122.00
50	18	80					
50	20	80	663015.144	122.00	63	663018 144	122.00
50	25	100	663015.152	132.00	80	663018 152	132.00
50	32	105	663015.156	136.00	80	663018 156	136.00
50	40	110	663015.160	141.00	90	663018 160	141.00

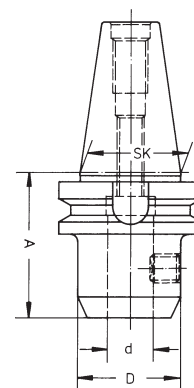

**663018..  
DIN 2080**

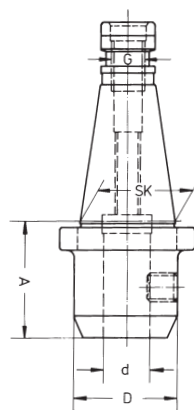

**Zwischenhülsen für MK mit Austreibblappen nach DIN 6383**

**Douilles intermédiaires p.outils à cône Morse DIN 6383**

**Adapter sleeves for Morse taper (MT) with tang accor- DIN 6383**

**6625..  
DIN 2080**

Steilkegel/cône taper DIN 2080 SK	MK	Best. Nr. no.cde		CHF	
		A	D		
30	1	50	25	6625. 002	64.00
30	2	50	32	6625. 004	64.00
30	3	75	40	6625. 006	64.00
40	1	50	25	6625. 020	64.00
40	2	50	32	6625. 022	64.00
40	3	65	40	6625. 024	64.00
40	4	95	48	6625. 026	70.00
50	1	45	25	6625. 102	90.00
50	2	60	32	6625. 108	90.00
50	3	65	40	6625. 114	90.00
50	4	70	48	6625. 120	90.00
50	5	105	63	6625. 126	100.00

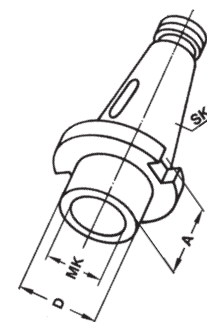

**662510..**  
**662520..**

**DIN 69871**  
**AD/AD/B**

**Zwischenhülsen für MK mit**  
**Aus-Treibblappen nach**  
**DIN 6383**

**Douilles interremédi-**  
**aires pour outils à**  
**cône Morse DIN 6383**

**Adapter sleeves for Morse**  
**taper (MT) with tang accor-**  
**DIN 6383**

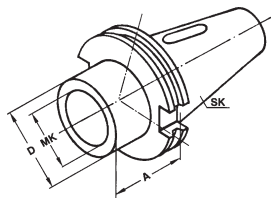

Steilkegel/cône taper DIN 69871 SK	MK	A	D	Best. Nr. n o.cde order no. Form AD	6.62510111 CHF
30	1	50	25	662510. 002	64.00
30	2	65	32	662510. 004	64.00
30	3	80	40	662510. 006	64.00
<b>Form AD/B</b>					
40	1	50	25	662520. 020	64.00
40	2	50	32	662520. 022	64.00
40	2	117	32	662520. 024	88.00
40	3	70	40	662520. 026	64.00
40	3	133	40	662520. 028	110.00
40	4	95	48	662520. 030	68.00
40	4	156	48	662520. 032	124.00
<b>Form AD</b>					
50	1	45	25	662520. 102	86.40
50	2	60	32	662520. 108	86.40
50	2	117	32	662520. 114	210.00
50	3	65	40	662520. 120	86.40
50	3	137	40	662520. 124	210.00
50	4	95	48	662520. 126	86.40
50	4	167	48	662520. 128	232.00
50	5	105	63	662520. 130	95.40
50	5	197	63	662520. 132	246.00

**663205.. AD**  
**663208..AD/B**  
**DIN 69871**

**Kombiaufsteckfräserdorne**  
**DIN 6358 DIN 69871AD/B**

**Porte fraises pour fraises à**  
**entraînement par clavette**  
**ou tenon selon DIN 6358,**  
**DIN 69871AD/B**

**Combi shell mill holders**  
**DIN 6358 / DIN 69871 AD/B**

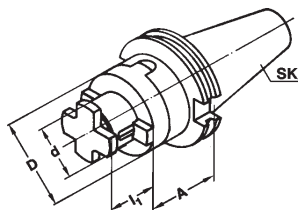

SK cône taper Form AD	Dorn douille arbor d [mm]	A	l1	D	Best. Nr. no.cde order no. Form AD	6.63205111 CHF
30	16	50	17	32	663205. 002	69.50
30	22	50	19	40	663205. 004	71.30
30	27	55	21	48	663205. 006	71.30
30	32	60	24	58	663205. 008	71.30
<b>Form AD/B</b>						
40	16	55	17	32	663208. 020	83.70
40	16	100	17	32	663208. 022	110.20
40	16	160	17	32	663208. 023	110.20
40	22	55	19	40	663208. 024	79.95
40	22	100	19	40	663208. 026	112.10
40	27	55	21	48	663208. 028	79.95
40	27	100	21	48	663208. 030	114.00
40	32	60	24	58	663208. 032	79.95
40	32	100	24	58	663208. 034	119.70
40	40	60	27	70	663208. 036	99.00
40	40	100	27	70	663208. 038	134.90
<b>Form AD</b>						
50	16	55	17	32	663208. 102	108.00
50	16	100	17	32	663208. 108	129.00
50	22	55	19	40	663208. 114	108.00
50	22	100	19	40	663208. 120	129.00
50	27	55	21	48	663208. 126	116.00
50	27	100	21	48	663208. 132	129.00
50	32	55	24	58	663208. 138	115.00
50	32	100	24	58	663208. 144	135.00
50	40	55	27	70	663208. 150	129.00
50	40	100	27	70	663208. 152	149.00

**Lieferumfang:**  
Inkl. Mitnehmerkeil, Mitnehmer-  
ring und Fräseranzugsschraube

**Inclus:**  
Clavette, bague d'entraine-  
ment et vis de serrage

**Delivery:**  
With retaining screw, driving ring  
and feather key

Gewindeschneid-Schnell-  
wechsel-futter mit Längen-  
ausgleich auf Druck und Zug

Appareil à tarauder avec  
compensation longitudinale à  
compression et traction

Quick change tapping chucks  
with length compensation on  
compression and expansion

**6633.10..**

SK	Spannbereich Capacité calmping range	A	D	d	C	T	Best.Nr./order no. no.cde. DIN 69871 A	6.633.10111 CHF
SK30	M3 - M14	65	38	19	7	7	6633. 101	369.00
SK30	M5 - M22	103	54	31	12	12	6633. 102	394.00
SK40	M3 - M14	59	38	19	7	7	6633. 104	268.00
SK40	M5 - M22	97	54	31	12	12	6633. 105	268.00
SK50	M3 - M14	50	38	19	7	7	6633. 108	381.00
SK50	M5 - M22	82	54	31	12	12	6633. 109	398.00

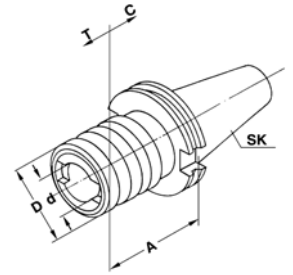

Gewindeschneid-Schnell-  
wechsel-futter ohne Längen-  
ausgleich auf Druck und Zug

Appareil à tarauder sans  
compensation longitudinale à  
compression et traction

Quick change tapping chucks  
without length compensation  
on compression & expansion

**6633.20..**

SK	Spannbereich Capacité clamping range	A	D	d	Best.Nr./order no.cde. DIN 69871 A	6.633.20111 CHF
SK30	M3 - M14	58	38	19	6633. 201	276.00
SK30	M5 - M22	93	54	31	6633. 202	297.00
SK40	M3 - M14	62	38	19	6633. 204	276.00
SK40	M5 - M22	95	54	31	6633. 205	297.00
SK50	M3 - M14	60	38	19	6633. 208	367.00
SK50	M5 - M22	85	54	31	6633. 209	385.00

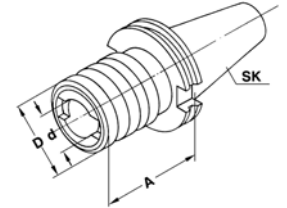

Gewindeeinsätze mit Rutsch-  
kupplung M3 - M14, Grösse 1

Douilles avec limiteur de  
couple M3 - M14, taille 1

Quick change adapters with  
safety clutch size 1

**5960.10..**

D	d	l1	M	DIN	Schaft tiege shank	Vierk. carré square	Best.Nr. no.cde. order no.	5.960.10111 CHF
32	19	25	M3	371	3.5	2.7	5960. 101	63.60
32	19	25	M3.5	371	4.0	3.0	5960. 102	63.60
32	19	25	M4	371	4.5	3.4	5960. 103	63.60
32	19	25	M5	371	6.0	4.9	5960. 104	63.60
32	19	25	M6	371	6.0	4.9	5960. 105	63.60
32	19	25	M8	371	8.0	6.2	5960. 106	63.60
32	19	25	M10	376	7.0	5.5	5960. 107	90.20
32	19	25	M10	371	10.0	8.0	5960. 108	90.20
32	19	25	M12	376	9.0	7.0	5960. 109	90.20
32	19	25	M14	376	11.0	9.0	5960. 110	90.20

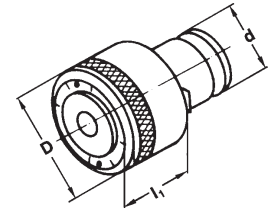

Gewindeeinsätze Gr. 1 ohne  
Rutschkupplung M3 - M14

Douilles sans limiteur de  
couple M3 - M14, taille 1

Quick change adapters  
without safety clutch size 1

**5960.30..**

D	d	l1	M	DIN	Schaft tiege shank	Vierk. carré square	Best.Nr. no.cde. order no.	5.960.30111 CHF
30	19	5	M3	371	3.5	2.7	5960. 301	28.70
30	19	5	M3.5	371	4.0	3.0	5960. 302	28.70
30	19	5	M4	371	4.5	3.4	5960. 303	28.70
30	19	5	M5	371	6.0	4.9	5960. 304	28.70
30	19	5	M6	371	6.0	4.9	5960. 305	28.70
30	19	5	M8	371	8.0	6.2	5960. 306	28.70
30	19	5	M10	376	7.0	5.5	5960. 307	28.70
30	19	5	M10	371	10.0	8.0	5960. 308	28.70
30	19	5	M12	376	9.0	7.0	5960. 309	41.00
30	19	5	M14	376	11.0	9.0	5960. 310	41.00

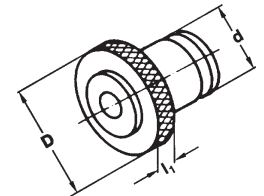

Gewindeeinsätze mit Rutsch-  
kupplung M5 - M22 Grösse 2

Douilles avec limiteur de  
couple M5 - M22, taille 2

Quick change adapters with  
safety clutch, size 2

**5960.50..**

D	d	l1	M	DIN	Schaft tiege shank	Vierk. carré square	Best.Nr. no.cde. order no.	5.960.50111 CHF
50	31	31	M5	371	6	4.9	5960. 501	90.20
50	31	31	M6	371	6	4.9	5960. 502	90.20
50	31	31	M8	371	8	6.2	5960. 503	90.20
50	31	31	M10	376	7	5.5	5960. 504	90.20
50	31	31	M10	371	10	8.0	5960. 505	90.20
50	31	31	M12	376	9	7.0	5960. 506	90.20
50	31	31	M14	376	11	9.0	5960. 507	90.20
50	31	31	M16	376	12	9.0	5960. 508	90.20
50	31	31	M18	376	14	11.0	5960. 509	90.20
50	31	31	M20	376	16	12.0	5960. 510	90.20
50	31	31	M22	376	18	14.5	5960. 511	90.20

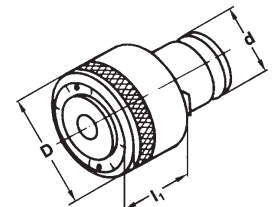

Gewindeeinsätze ohne Rutsch-  
kupplung M5 - M22, Grösse 2

Douilles sans limiteur de  
couple M5 - M22, taille 2

Quick change adapters  
without safety clutch size 2

**5960.70..**

D	d	l1	M	DIN	Schaft tiege shank	Vierk. carré square	Best.Nr. no.cde. order no.	5.960.70111 CHF
48	31	6	M5	371	6	4.9	5960. 701	41.00
48	31	6	M6	371	6	4.9	5960. 702	41.00
48	31	6	M8	371	8	6.2	5960. 703	41.00
48	31	6	M10	376	7	5.5	5960. 704	41.00
48	31	6	M10	371	10	8.0	5960. 705	41.00
48	31	6	M12	376	9	7.0	5960. 706	41.00
48	31	6	M14	376	11	9.0	5960. 707	41.00
48	31	6	M16	376	12	9.0	5960. 708	41.00
48	31	6	M18	376	14	11.0	5960. 709	41.00
48	31	6	M20	376	16	12.0	5960. 710	41.00
48	31	6	M22	376	18	14.5	5960. 711	41.00

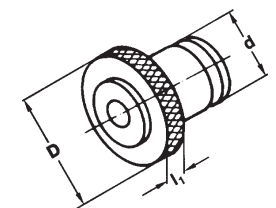



Spannzangenfutter

Mandrin de serrage

Collet chucks



- Zum Spannen von Werkzeugen mit Zylinderschaft in Spannzangen DIN 6499 ER
- Lieferumfang: komplett mit Spannmutter, Ausgewuchtet mit G 6.3 bei 12'000 U/min
- ab ER 25 kugelgelagerte Spannmutter gegen Aufpreis möglich
- zentrale Kühlmittelzufuhr Form A D oder AD/B mit lösbarem Gewindestift

- Mandrin de serrage pour fraises cylindriques selon DIN 6499 ER
- Livraison: complete avec écrou Équilibré à G 6.3 à 10'000 rev./min.
- A partir de ER 25 écrou de serrage à roulement à bille possible
- Lubrification centrale Form AD ou AD/B à goupille démontable

- For mounting straight shank tools in collets according DIN 6499 ER
- Delivery with clamping nut, balanced with G 6.3 at 12'000 rev./min
- Bballbearing based nut possible against surcharge from collets ER 25 onwards
- coolant through center according Form A D or AD/B with removable threaded pin

680505..SK 30/40/50  
DIN 69871 Form AD-AD/B

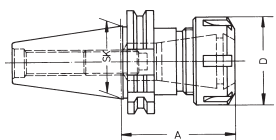

Spannzangengrösse ER dimension de la pince collet size SK	16		25		32		40	
	Best.Nr. no.cde order no.	Fr.	Best.Nr. no.cde order no.	CHF	Best.Nr. no.cde order no.	CHF	Best.Nr. no.cde order no.	CHF
SK 30	70 680505.00	86.00	70 680505.02	86.00	70 680505.04	90.20	70 680505.61	96.40
SK 30	100 680505.01	98.40	100 680505.03	108.70	100 680505.60	108.70		
SK 40	63 680505.05	87.00	60 680505.10	87.00	70 680505.20	87.00	80 680505.30	95.00
SK 40	100 680505.07	98.40	100 680505.14	108.70	100 680505.23	108.70	100 680505.31	121.00
SK 40	160 680505.09	164.00	160 680505.18	164.00	160 680505.27	168.10	160 680505.32	176.30
SK 50	63 680505.33	138.00	60 680505.37	138.00	70 680505.40	145.00	80 680505.50	155.00
SK 50	100 680505.34	164.00	100 680505.38	164.00	100 680505.43	108.70	100 680505.54	198.90
SK 50	160 680505.35	233.50	160 680505.39	164.00	160 680505.45	168.10	160 680505.58	229.60
Durchmesser/diam. D	32		42		50		63	
Spannbereich/capacité	1.0 - 10.0		2.0 - 16.0		2.0 - 20.0		3.0 - 26.0	

680510.. SK 30/40/50  
MAS/BT Form AD-AD/B

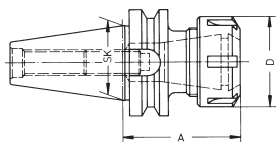

Spannzangengrösse ER dimension de la pince collet size SK	16		25		32		40	
	Best.Nr. no.cde order no.	CHF	Best.Nr. no.cde order no.	CHF	Best.Nr. no.cde order no.	CHF	Best.Nr. no.cde order no.	CHF
BT 30	70 680510.00	86.00	70 680510.04	86.00	70 680510.05	90.20	70 680510.06	96.40
BT 30	100 680510.02	98.40						
BT 40	63 680510.07	87.00	60 680510.10	87.00	70 680510.20	87.00	80 680510.30	95.00
BT 40	100 680510.08	98.40			100 680510.22	108.70		
BT 40	160 680510.09	118.90						
BT 50			70 680510.38	86.10	70 680510.40	135.00	80 680510.50	135.00
BT 50								
BT 50								
Durchmesser/diam. D	32		42		50		63	
Spannbereich/capacité	1.0 - 10.0		2.0 - 16.0		2.0 - 20.0		3.0 - 26.0	

680515.. SK 30/40/50  
DIN 2080

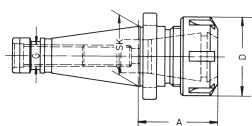

Spannzangengrösse ER dimension de la pince collet size	25		32		40	
	Best.Nr. no.cde order no.	CHF	Best.Nr. no.cde order no.	CHF	Best.Nr. no.cde order no.	CHF
SK 30	680515.00	87.00	680120.993	90.20		
SK 40	680515.10	87.00	680515.20	90.20	680515.30	96.40
SK 50			680515.40	177.00	680515.50	177.00
Länge A/longu./length A	50		50/ 63		63	
Durchmesser/diam. D	42		50		63	
Spannbereich capacité/range	2.0 - 16.0		2.0 - 20.0		4.0 - 26.0	
6.80515111	Inklusive Spann- und Abziehmutter/ écrou de serrage inclus /nut included					

Weitere Werkzeugaufnahmen und Zubehöre auf Anfrage  
Autre outils de serrage et d'accessoires sur demande  
Additional tool holders and accessories on request

**Werkzeugaufnahmen  
HSK-A DIN 69893-1 (ISO  
12164-1)Form A**

Werkstoff: legierter Einsatzstahl mit Zugfestigkeit im Kern von min. 1000 N/mm<sup>2</sup>. Einsatzgehärtet HRC 60±2 (HV 700 ± 50), Härtetiefe 0.8 mm± 0.2 mm, brüniert.  
Genauigkeit: Kegelwinkel-Toleranz < AT3 nach DIN 7187, max.  
**Vorgewuchtet G 6.3 15.000** min-1, G2.5 Feinwuchten gegen Aufpreis

**Porte-outils HSK-A selon  
DIN 69893-1 (ISO 12164-1)  
forme A**

Chassis d'allié en acier de cementation. Résistance à la traction dans le noyau de min. 1000 N/mm<sup>2</sup>. Cementé HRC 60 ± 2 (HV 700 ± 50), épaisseur de cementation 0.8 mm ± 0.2 mm, bruni.  
Précision: Angle du cône < AT 3 d'après DIN 7187  
**Pré-équilibré G 6.3 15.000** min-1 G 2.5 Equilibrage fin contre un supplément

**Toolholders DIN 69893-1  
(ISO 12164-1) Form A**

Material: Alloyed case-hardened steel, tensile core strength of min. 1000 N/mm<sup>2</sup>. Case hardened HRC 60± 2 (HV 700 ± 50), hardening depth 0.8 mm± 0.2 mm, blackened and precision ground.  
Genauigkeit: Tolerance of taper < AT3 according DIN 7187  
**Pre-balanced G 6.3 15'000** min-1 G 2.5 Fine balancing at extra charge

**6635HSK..**

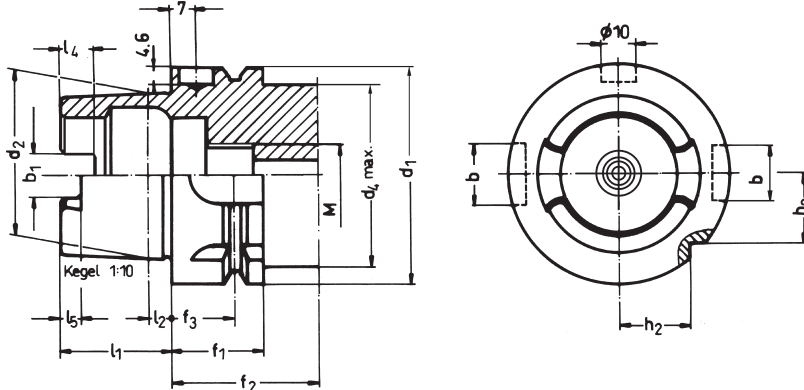

HSK-A													6.635HSKTAB		
d1	d2	d4	l1	l2	l4	l5	M	f1	f2	f3	b1	b2	b3		
32	24	26	16	3.2	5	3	M10x1	20	35	16	7.05	7	9		
40	30	34	20	4.0	6	3.5	M12x1	20	35	16	8.05	9	11		
50	38	42	25	5.0	7.5	4.5	M16x1	26	42	18	10.54	12	14		
63	48	53	32	6.3	10	6	M18x1	26	42	18	12.54	16	18		
80	60	67	40	8.0	12	8	M20x1.5	26	42	18	16.04	18	20		
100	75	85	50	10.0	15	10	M24x1.5	29	45	20	20.02	22	20		

**Fräseraufnahmen für Zy-  
linderschäfte DIN 1835-B f.  
HSK-32/50**

**Porte-fraises DIN 6359 pour  
Weldon DIN 1835-B, HSK-  
32/50**

**End mill holders acc.DIN  
6359 for end mills acc.DIN  
1835-B for HSK-32/50**

**6635HSK.13..**  
DIN 6359

d	A	D	Best.Nr. no.cde. order no.	6.635HSK.13111 CHF
<b>HSK-A 32</b>				
6	60	25	6635HSK. 131	166.00
8	60	28	6635HSK. 132	160.00
10	65	35	6635HSK. 133	160.00
12	65	42	6635HSK. 134	**
<b>HSK-A 40</b>				
6	60	25	6635HSK. 136	**
8	60	28	6635HSK. 137	**
10	60	35	6635HSK. 138	**
12	70	42	6635HSK. 139	**
16	75	48	6635HSK. 140	**
<b>HSK-A 50</b>				
6	65	25	6635HSK. 142	**
8	65	28	6635HSK. 143	**
10	65	35	6635HSK. 144	**
12	80	42	6635HSK. 145	**
14	80	44	6635HSK. 146	**
16	80	48	6635HSK. 147	**
18	80	50	6635HSK. 148	**
20	80	52	6635HSK. 149	""

\*\* Preise auf Anfrage/prix sur demande/prices on request

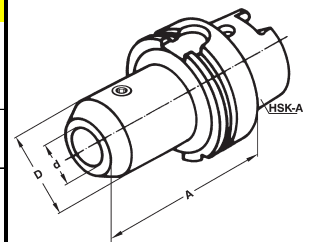

**6635HSK.15..**

DIN 6359

Fräseraufnahme DIN 6359 f. Porte-fraises DIN 6359  
Zyl.-Schäfte DIN 1835-B, pour Weldon DIN 1835-B,  
HSK-63/100 HSK-63/100

End mill holders acc. DIN  
6359 for end mills acc. DIN  
1835-B for HSK-63/100

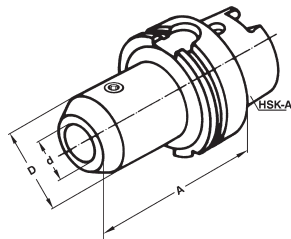

d	A	D	Best.Nr. no.cde. order no.	6.635HSK.15111 CHF
<b>HSK-A 63</b>				
6	65	25	6635HSK. 151	174.30
6	100	25	6635HSK. 152	190.70
8	65	28	6635HSK. 153	174.30
8	100	28	6635HSK. 154	190.70
10	65	35	6635HSK. 155	174.30
10	100	35	6635HSK. 156	190.70
12	80	42	6635HSK. 157	174.30
12	100	42	6635HSK. 158	190.70
14	80	44	6635HSK. 159	174.30
14	100	44	6635HSK. 160	190.70
16	80	48	6635HSK. 161	174.30
16	100	48	6635HSK. 162	190.70
18	80	50	6635HSK. 163	174.30
18	100	50	6635HSK. 164	190.70
20	80	52	6635HSK. 165	174.30
25	110	65	6635HSK. 166	205.00
32	110	72	6635HSK. 167	217.30
40	125	80	6635HSK. 168	237.80
<b>HSK-A 80</b> ** Preis auf Anfrage/prix s. demande/ price on request				
6	80	25	6635HSK. 172	**
8	80	28	6635HSK. 173	**
10	80	35	6635HSK. 174	**
12	80	42	6635HSK. 175	**
14	80	44	6635HSK. 176	**
16	100	48	6635HSK. 177	**
18	100	50	6635HSK. 178	**
20	100	52	6635HSK. 179	**
25	100	65	6635HSK. 180	**
32	100	72	6635HSK. 181	**
<b>HSK-A 100</b>				
6	80	25	6635HSK. 182	242.00
8	80	28	6635HSK. 184	242.00
10	80	35	6635HSK. 186	242.00
12	80	42	6635HSK. 187	242.00
14	80	44	6635HSK. 189	242.00
16	100	48	6635HSK. 190	242.00
18	100	50	6635HSK. 192	242.00
20	100	52	6635HSK. 194	242.00
25	100	65	6635HSK. 196	283.00
32	100	72	6635HSK. 198	299.00
40	105	80	6635HSK. 199	320.00



Fräseraufnahmen mit  
Kühlkanal f. Zylinderschäfte  
DIN 1835-B für HSK-A 63

Porte-fraises DIN 6359 à  
canal d'arrosage pour  
Weldon DIN 1835-B pour  
HSK-A 63

End mill holders acc. DIN  
6359 with cooland chan-  
nels for end mills acc. DIN  
1835-B for HSK-63

**6635HSK.21..**  
DIN 6359

d	A	D	Best.Nr. no.cde. order no.	6.635HSK.21111 CHF
<b>HSK-A 63</b>				
6	65	25	6635HSK. 211	149.00
8	65	28	6635HSK. 212	149.00
10	65	35	6635HSK. 214	149.00
12	80	42	6635HSK. 215	149.00
14	80	44	6635HSK. 216	149.00
16	80	48	6635HSK. 217	149.00
18	80	50	6635HSK. 218	149.00
20	80	52	6635HSK. 219	149.00
25	110	65	6635HSK. 220	177.00
32	110	72	6635HSK. 221	186.00
40	125	80	6635HSK. 222	203.00

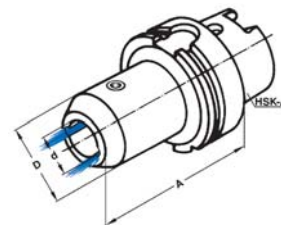

Andere HSK-Typen auf Anfrage / autres types HSK sur demande/other types on request

Fräseraufnahmen Whistle  
Notch DIN 1835-E für  
HSK-A 63

Porte fraises Whistle Notch  
pour que. cyl. DIN 1835-E et  
HSK-A 63

End mill holders acc. DIN  
6359 acc. DIN 1835-E  
(Whistle Notch) f. HSK-A63

**6635HSK.25..**  
DIN 6359

d	A	D	Best.Nr. no.cde. order no.	6.635HSK.25111 CHF
<b>HSK-A 63</b>				
6	80	25	6635HSK. 251	174.25
8	80	28	6635HSK. 252	174.25
10	80	35	6635HSK. 253	174.25
12	90	42	6635HSK. 254	174.25
14	90	44	6635HSK. 255	174.25
16	100	48	6635HSK. 256	174.25
18	100	50	6635HSK. 257	174.25
20	100	52	6635HSK. 258	174.25
25	110	65	6635HSK. 259	205.00
32	110	72	6635HSK. 260	217.30

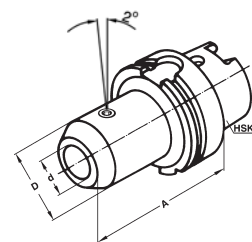

Andere HSK-Typen auf Anfrage / autres types HSK sur demande/other types on request

Kombi-Aufsteckfräserdorne  
DIN 6358 für HSK-A 63

Porte fraises à double usa-  
ge pour fraises à entraîne-  
ment par clavette ou tenon  
DIN 6358

Combi shell mill holders  
DIN 6358 for HSK-A 63

**6635HSK.26..**  
DIN 6358

d	A	I1	D	Best.Nr. no.cde. order no.	6.635HSK.26111 CHF
<b>HSK-A 63</b>					
16	60	17	32	6635HSK. 261	192.70
16	100	17	32	6635HSK. 262	233.70
22	60	19	40	6635HSK. 263	192.70
22	100	19	40	6635HSK. 264	233.70
27	60	21	48	6635HSK. 265	198.90
27	100	21	48	6635HSK. 266	239.90
32	60	24	58	6635HSK. 267	211.20
32	100	24	58	6635HSK. 268	256.00
40	70	27	70	6635HSK. 269	229.00

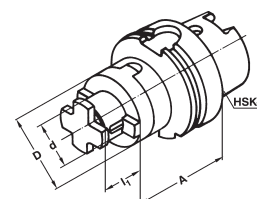

Andere HSK-Typen auf Anfrage / autres types HSK sur demande/other types on request

**6635HSK.28..**  
DIN 6357

Quernut-Aufsetzdorne DIN 6357 m. vergrößerter Anlagefläche u. Kühlkanalbohrungen an der Stirnseite

Porte-fraises à surfer DIN 6357 avec diamètre de collerette élargi et conduits pour l'arrosage frontal

Shell mill holder DIN 6357 with enlarged contact face and coolant exit bores on the end face

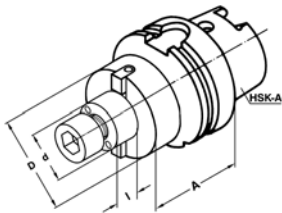

d	A	l	D	Best.Nr. no.cde./ order no.	6.635HSK.28111 CHF
<b>HSK-A 63</b>					
16	50	17	38	6635HSK. 280	205.00
16	100	17	38	6635HSK. 281	248.00
22	50	19	48	6635HSK. 282	205.00
22	100	19	48	6635HSK. 283	248.00
27	60	21	58	6635HSK. 284	205.00
27	100	21	58	6635HSK. 285	248.00
32	60	24	78	6635HSK. 286	211.00
32	100	24	78	6635HSK. 287	256.00
40 *	60	27	88	6635HSK. 288	269.00
40 *	100	27	88	6635HSK. 289	316.00

\* Mit zusätzlichen 4 Gewindebohrungen/avec 4 trous taraudés supplémentaires selon DIN 2079  
with 4 additional threaded holes according DIN 2079

Andere HSK-Typen auf Anfrage / autres types HSK sur demande / other HSK-types on request

**6635HSK.30..**  
DIN 6383

Zwischenhülsen für MK mit Austreibblappen DIN 6383

Douilles intermédiaires pour outils à cône Morse MK DIN 6383

Adaptor sleeves for MT with tang DIN 6383

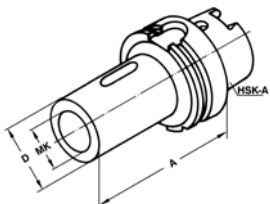

MK	A	D	Best.Nr. no.cde./ order no.	6.635HSK.30111 CHF
<b>HSK-A 63</b>				
1	100	25	6635HSK. 301	162.00
2	120	32	6635HSK. 302	162.00
3	140	40	6635HSK. 303	166.00
4	160	48	6635HSK. 304	170.00

Andere HSK-Typen auf Anfrage / autres types HSK sur demande / other HSK-types on request

**6635HSK.32..**  
DIN 6364

Zwischenhülsen für MK mit Anzugsgewinde DIN 6364

Douilles intermédiaires pour outils à cône Morse à trous filetés DIN 6364

Adaptor sleeves for MT with drawbar thread DIN 6364

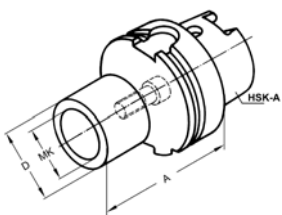

MK	A	D	Best.Nr. no.cde./ order no.	6.635HSK.30111 CHF
<b>HSK-A 63</b>				
1	100	25	6635HSK. 301	162.00
2	120	32	6635HSK. 302	162.00
3	140	40	6635HSK. 303	166.00
4	160	48	6635HSK. 304	170.00

Andere HSK-Typen auf Anfrage / autres types HSK sur demande / other HSK-types on request

**6635HSK.35..**

Gewindeschneid-Schnellwechsel-futter mit Längenausgleich auf Druck und Zug

Appareil à tarauder avec compensation longitudinale

Quick change tapping chucks with length compensation on compression and decompression

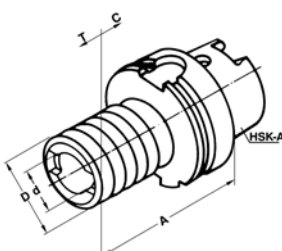

D	d	A	D	d	C	T	Best.Nr. no.cde./order no.	6.635HSK.35111 CHF
32	19	72	38	19	7	7	6635HSK. 351	772.00
32	19	110	54	31	12	12	6635HSK. 352	845.00

Gewindeschneid-Schnellwechselfutter *ohne* Längenausgleich auf Druck und Zug

Appareil à tarauder sans compensation longitudinale à compression et traction

Quick change tapping chucks without length compensation on compression & expansion

**6635HSK.38..**  
DIN 6359

Spannbereich capacité			Best.Nr. no.cde.		6.635HSK.3625 Fr.
A	D	d			
<b>HSK-A 63</b>					
M3 - M14	65	38	19	<b>6635HSK. 361</b>	<b>422.00</b>
M5 - M22	100	54	31	<b>6635HSK. 362</b>	<b>443.00</b>

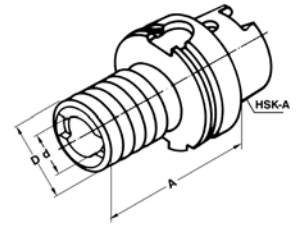

Andere HSK-Typen auf Anfrage / autres types HSK sur demande / other types on request

Gewindeeinsätze *mit* Rutschkupplung M3 - M14, Grösse 1

Douilles avec limiteur de couple M3 - M14, taille 1

Quick change adapters with safety clutch M3-M14 size 1

**5960.10..**

D	d	l1	M	DIN	Schaft tiege shank	Vierk. carré square	Best.Nr. no.cde. order no.	5.960.10111 CHF
32	19	25	M3	371	3.5	2.7	<b>5960. 101</b>	<b>63.60</b>
32	19	25	M3.5	371	4.0	3.0	<b>5960. 102</b>	<b>63.60</b>
32	19	25	M4	371	4.5	3.4	<b>5960. 103</b>	<b>63.60</b>
32	19	25	M5	371	6.0	4.9	<b>5960. 104</b>	<b>63.60</b>
32	19	25	M6	371	6.0	4.9	<b>5960. 105</b>	<b>63.60</b>
32	19	25	M8	371	8.0	6.2	<b>5960. 106</b>	<b>63.60</b>
32	19	25	M10	376	7.0	5.5	<b>5960. 107</b>	<b>90.20</b>
32	19	25	M10	371	10.0	8.0	<b>5960. 108</b>	<b>90.20</b>
32	19	25	M12	376	9.0	7.0	<b>5960. 109</b>	<b>90.20</b>
32	19	25	M14	376	11.0	9.0	<b>5960. 110</b>	<b>90.20</b>

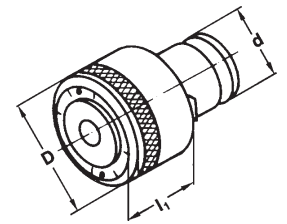

Gewindeeinsätze Gr. 1 *ohne* Rutschkupplung M3 - M14

Douilles sans limiteur de couple M3 - M14, taille 1

Quick change adapters without safety clutch M3-M14 size1

**5960.30..**

D	d	l1	M	DIN	Schaft tiege shank	Vierk. carré square	Best.Nr. no.cde. order no.	5.960.30111 CHF
30	19	5	M3	371	3.5	2.7	<b>5960. 301</b>	<b>28.70</b>
30	19	5	M3.5	371	4.0	3.0	<b>5960. 302</b>	<b>28.70</b>
30	19	5	M4	371	4.5	3.4	<b>5960. 303</b>	<b>28.70</b>
30	19	5	M5	371	6.0	4.9	<b>5960. 304</b>	<b>28.70</b>
30	19	5	M6	371	6.0	4.9	<b>5960. 305</b>	<b>28.70</b>
30	19	5	M8	371	8.0	6.2	<b>5960. 306</b>	<b>28.70</b>
30	19	5	M10	376	7.0	5.5	<b>5960. 307</b>	<b>28.70</b>
30	19	5	M10	371	10.0	8.0	<b>5960. 308</b>	<b>28.70</b>
30	19	5	M12	376	9.0	7.0	<b>5960. 309</b>	<b>41.00</b>
30	19	5	M14	376	11.0	9.0	<b>5960. 310</b>	<b>41.00</b>

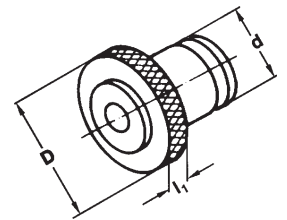

Gewindeeinsätze *mit* Rutschkupplung M5 - M22 Grösse 2

Douilles avec limiteur de couple M5 - M22, taille 2

Quick change adapters with safety clutch, M5-M22, size 2

**5960.50..**

D	d	l1	M	DIN	Schaft tiege shank	Vierk. carré square	Best.Nr. no.cde. order no.	5.960.50111 CHF
50	31	31	M5	371	6	4.9	<b>5960. 501</b>	<b>90.20</b>
50	31	31	M6	371	6	4.9	<b>5960. 502</b>	<b>90.20</b>
50	31	31	M8	371	8	6.2	<b>5960. 503</b>	<b>90.20</b>
50	31	31	M10	376	7	5.5	<b>5960. 504</b>	<b>90.20</b>
50	31	31	M10	371	10	8.0	<b>5960. 505</b>	<b>90.20</b>
50	31	31	M12	376	9	7.0	<b>5960. 506</b>	<b>90.20</b>
50	31	31	M14	376	11	9.0	<b>5960. 507</b>	<b>90.20</b>
50	31	31	M16	376	12	9.0	<b>5960. 508</b>	<b>90.20</b>
50	31	31	M18	376	14	11.0	<b>5960. 509</b>	<b>90.20</b>
50	31	31	M20	376	16	12.0	<b>5960. 510</b>	<b>90.20</b>
50	31	31	M22	376	18	14.5	<b>5960. 511</b>	<b>90.20</b>

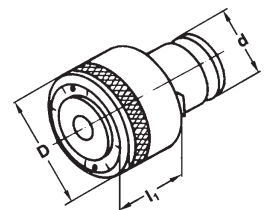

Gewindeeinsätze *ohne* Rutschkupplung M5 - M22, Grösse 2

Douilles sans limiteur de couple M5 - M22, taille 2

Quick change adapters without safety clutch M5-M22, size2

**5960.70..**

D	d	l1	M	DIN	Schaft tiege shank	Vierk. carré square	Best.Nr. no.cde. order no.	5.960.70111 CHF
48	31	6	M5	371	6	4.9	<b>5960. 701</b>	<b>41.00</b>
48	31	6	M6	371	6	4.9	<b>5960. 702</b>	<b>41.00</b>
48	31	6	M8	371	8	6.2	<b>5960. 703</b>	<b>41.00</b>
48	31	6	M10	376	7	5.5	<b>5960. 704</b>	<b>41.00</b>
48	31	6	M10	371	10	8.0	<b>5960. 705</b>	<b>41.00</b>
48	31	6	M12	376	9	7.0	<b>5960. 706</b>	<b>41.00</b>
48	31	6	M14	376	11	9.0	<b>5960. 707</b>	<b>41.00</b>
48	31	6	M16	376	12	9.0	<b>5960. 708</b>	<b>41.00</b>
48	31	6	M18	376	14	11.0	<b>5960. 709</b>	<b>41.00</b>
48	31	6	M20	376	16	12.0	<b>5960. 710</b>	<b>41.00</b>
48	31	6	M22	376	18	14.5	<b>5960. 711</b>	<b>41.00</b>

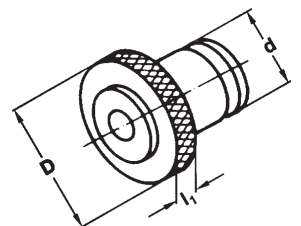

**6635HSK.38..**

Hydrodehnspannfutter

Mandrin expansibles  
hydrauliques

Hydraulic expansion  
chucks

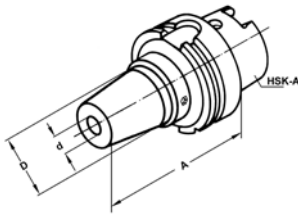

			Best.Nr. 6.635HSK.38111	
			no.cde./order no.	CHF
<b>HSK-A 63</b>				
d	A	D		
6	80	50	6635HSK. 381	826.00
8	80	50	6635HSK. 382	826.00
10	85	50	6635HSK. 383	826.00
12	90	50	6635HSK. 384	826.00
14	90	50	6635HSK. 385	826.00
16	95	50	6635HSK. 386	826.00
18	95	50	6635HSK. 387	826.00
20	100	50	6635HSK. 388	826.00
25	115	53	6635HSK. 389	826.00
32	120	53	6635HSK. 390	826.00

Zubehör: Reduzierungen; Accessoires: Douilles de réduction; accessories: reduction sleeves

**6635.39..**

Reduzierhülsen für  
Hydrodehnspannfutter

Douilles de réduction p.  
mandrin expansibles hy-  
drauliques

Reduction sleeves for  
hydraulic expansion  
chucks

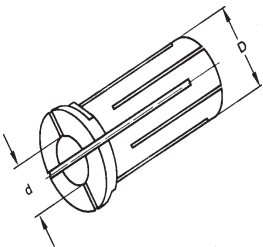

		Best.Nr. 6.635.39111	
		no.cde./order no.	CHF
D	d		
20	3	6635. 390	141.45
20	4	6635. 391	141.45
20	5	6635. 392	141.45
20	6	6635. 393	131.20
20	8	6635. 394	131.20
20	10	6635. 395	131.20
20	12	6635. 396	131.20
20	14	6635. 397	131.20
20	16	6635. 398	131.20

**6635HSK.42..**

NC-Bohrfutter für Rechts-  
und Linkslauf

Mandrin à serrage rapide  
NC pour rotation à droite  
et à gauche

CNC-Drill chucks for clock-  
wise and counter clockwise  
rotation

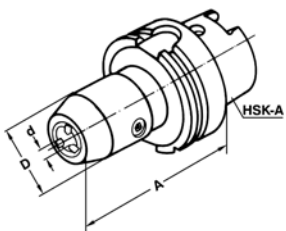

			Best.Nr. 6.635HSK.42111	
			no.cde./order no.	CHF
<b>HSK-A 63</b>				
d	A	D		
1 - 13	104	50	6635HSK. 421	748.00
3 - 16	104	57	6635HSK. 422	826.00
1 - 13*	104	50	6635HSK. 383	783.00
3 - 16*	104	57	6635HSK. 384	854.00

\*Mit zentraler Kühlmittelzufuhr/Liquide de refroidissement par le centre/coolant through the centre

Andere HSK-Typen auf Anfrage / autres types HSK sur demande / other HSK-types on request

**6635HSK.46..**

Spannfutter für Spannzan-  
gen DIN 6499 ER

Mandrin à pinces pour  
pinces ER selon DIN 6499

Collet chucks for collets  
acc. DIN 6499 ER

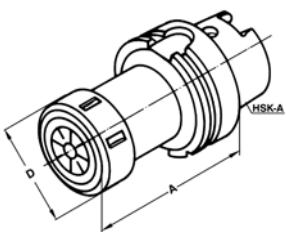

Spannbereich			Best.Nr. 6.635HSK.46111	
Capacité/range			no.cde./order no.	CHF
<b>HSK-A 63</b>				
A	D			
ER16 1 - 10	100	32	6635HSK. 461	168.00
ER25 2 - 16	100	42	6635HSK. 462	168.00
ER25 2 - 16	160	42	6635HSK. 463	248.00
ER32 2 - 20	100	50	6635HSK. 464	174.00
ER32 2 - 20	160	50	6635HSK. 465	256.00
ER40 2 - 26	120	63	6635HSK. 466	187.00
ER40 2 - 26	160	63	6635HSK. 467	275.00

Andere HSK-Typen auf Anfrage / autres types HSK sur demande / other HSK-types on request

Kühlmittelübergabeeinheit    Unité de transmission de    Coolant tube through the  
 liquide de refroidissement    centre  
 par le centre

**6635HSK.48..**

Typ type	D	d	L	Best.Nr. no.cde./order no.	6.635HSK.48111 CHF
HSK-A 63	M18 x 1	12	34.1	6635HSK. 361	24.60

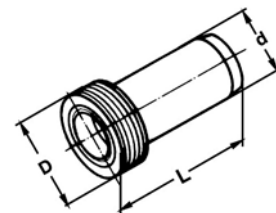

Andere HSK-Typen auf Anfrage / autres types HSK sur demande / other HSK types on request

Schlüssel für Übergabeeinheit    Clé pour raccord d'arrosage    Key for coolant tube  
 sage

**6635HSK.50..**

Typ type	D	L	Best.Nr. no.cde./order no.	6.635HSK.50111 CHF
HSK-A 63	16.5	136	6635HSK. 501	43.05

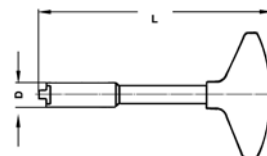

Andere HSK-Typen auf Anfrage / autres types HSK sur demande / other HSK types on request

Kontrolldorne DIN 69893    Mandrin de contrôle    Test arbors DIN 69893  
 DIN 69893

**6635HSK.52..**

Typ type	D	A	Best.Nr. no.cde./order no.	6.635HSK.52111 CHF
HSK-A 63	40	200	6635HSK. 521	195.00

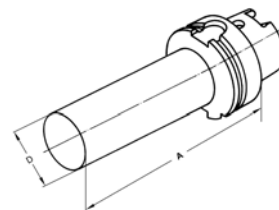

Andere HSK-Typen auf Anfrage / autres types HSK sur demande / other HSK types on request