

Gelötete HM-Drehstähle Burins brasés

- Hartmetallschneidflächen
- nach DIN 4950
- Schäfte aus unleg. Stahl 700-800 N/mm2

- Plaquettes en métal dur
- selon DIN 4950
- tiges en acier non allié 700-800 N/mm2

Turning tools carb. tipped

- Carbide inserts
- according DIN 4950
- Shanks from non alloyed steel 700-800 N/mm2

3717..

Lieferbare Hartmetallsorten: K10 für Gussbearbeitung u. NE-Metalle, P25 für Stahl- und Stahllegierungen, P40 für rostfreie Stähle

Nuances de métal dur livrables: Available carbide grades: K10 pour fonte et aciers non ferreux, P25 pour acier et alliages d'acier, P40 pour aciers inoxydables

Ger. HM-best. Schruppstähle ISO 1, DIN 4971

Burins d'éb. droits à mise en carbure ISO 1 DIN 4971 Straight carb. tipped rough turning tools ISO 1, DIN 4971

371701..

Schafthöhe hauteur tige shank hight mm	Schaftbreite largeur tige shank width mm	Gesamtlänge long. totale total length mm	Ausführ. / exec.		Hartmetallsorte nuance métal dur carbide grade			Best.Nr. no.cde. order no.	Preis prix price CHF
			rechts R à droite R right R	links L gauche L left L	K10	P25	P40		
10	10	90	R		K10			371701. 1010	7.60
			R			P25	P40	371701. 1020	7.60
			R					371701. 1040	8.40
12	12	100	R		K10			371701. 1015	7.60
			R			P25	P40	371701. 1025	7.60
			R					371701. 1210	8.80
16	16	100	R		K10			371701. 1220	8.80
			R			P25	P40	371701. 1240	9.80
			R					371701. 1215	8.80
20	20	125	R		K10			371701. 1225	8.80
			R			P25	P40	371701. 1245	9.80
			R					371701. 1610	10.20
25	25	140	R		K10			371701. 1620	10.20
			R			P25	P40	371701. 1640	11.40
			R					371701. 1615	10.20
32	32	170	R		K10			371701. 1625	10.20
			R			P25	P40	371701. 1645	11.40
			R					371701. 2010	13.20
40	40	200	R		K10			371701. 2020	13.20
			R			P25	P40	371701. 2040	14.60
			R					371701. 2015	13.20
3.71701RL29			R		K10			371701. 2025	13.20
			R			P25	P40	371701. 2045	14.60
			R					371701. 2510	21.30
45° Gebogene HM-bestückte Schruppstähle ISO 2, DIN 4972	45° bent carbide tipped roughing turning tools ISO 2, DIN 4972		R		K10			371701. 2520	21.30
			R			P25	P40	371701. 2540	22.80
			R					371701. 2515	21.30
3.71702RL29			R		K10			371701. 2525	21.30
			R			P25	P40	371701. 2545	22.80
			R					371701. 3210	31.90
45° Gebogene HM-bestückte Schruppstähle ISO 2, DIN 4972	45° bent carbide tipped roughing turning tools ISO 2, DIN 4972		R		K10			371701. 3220	31.90
			R			P25	P40	371701. 3240	35.20
			R					371701. 3215	31.90
3.71702RL29			R		K10			371701. 3225	31.90
			R			P25	P40	371701. 4010	57.60
			R					371701. 4020	57.60
3.71702RL29			R		K10			371701. 4040	63.40
			R			P25	P40	371701. 4015	57.60
			R					371701. 4025	57.60
3.71702RL29			R		K10			371701. 4045	63.40
			R			P25	P40		
			R						

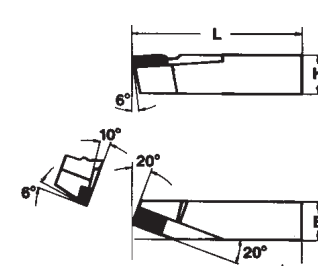
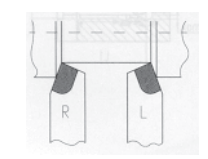

371702..

45° Gebogene HM-bestückte Schruppstähle ISO 2, DIN 4972

Schafthöhe hauteur tige shank hight mm	Schaftbreite largeur tige shank width mm	Gesamtlänge long. totale total length mm	Ausführ. / exec.		Hartmetallsorte nuance métal dur carbide grade			Best.Nr. no.cde. order no.	Preis prix price CHF
			rechts R à droite R right R	links L gauche L left L	K10	P25	P40		
10	10	90	R		K10			371702. 1010	8.00
			R			P25	P40	371702. 1020	8.00
			R					371702. 1040	8.80
12	12	100	R		K10			371702. 1015	8.00
			R			P25	P40	371702. 1025	8.00
			R					371702. 1045	8.80
16	16	100	R		K10			371702. 1210	9.30
			R			P25	P40	371702. 1220	9.30
			R					371702. 1240	10.20
20	20	125	R		K10			371702. 1215	9.30
			R			P25	P40	371702. 1225	9.30
			R					371702. 1245	10.20
25	25	140	R		K10			371702. 1610	10.70
			R			P25	P40	371702. 1620	10.70
			R					371702. 1640	11.80
32	32	170	R		K10			371702. 1615	10.20
			R			P25	P40	371702. 1625	10.70
			R					371702. 1645	11.80
40	40	200	R		K10			371702. 2010	13.60
			R			P25	P40	371702. 2020	13.60
			R					371702. 2040	15.25
3.71702RL29			R		K10			371702. 2015	13.60
			R			P25	P40	371702. 2025	13.60
			R					371702. 2045	15.00
3.71702RL29			R		K10			371702. 2510	21.40
			R			P25	P40	371702. 2520	21.40
			R					371702. 2540	23.70
3.71702RL29			R		K10			371702. 2515	21.40
			R			P25	P40	371702. 2525	21.40
			R					371702. 2545	23.70
3.71702RL29			R		K10			371702. 3210	32.10
			R			P25	P40	371702. 3220	32.10
			R					371702. 3240	35.30
3.71702RL29			R		K10			371702. 3215	32.10
			R			P25	P40	371702. 3225	32.10
			R					371702. 3245	35.30
3.71702RL29			R		K10			371702. 4010	58.10
			R			P25	P40	371702. 4020	58.10
			R					371702. 4040	64.00
3.71702RL29			R		K10			371702. 4015	58.10
			R			P25	P40	371702. 4025	58.10
			R					371702. 4045	64.00

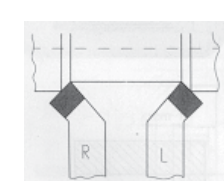
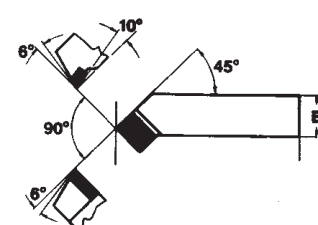

371703..

HM-bestückter Eckstahl Burins à dr. les angles C.tipped corner turning ISO A, ISO3, DIN 4978 MD ISO A,ISO3,DIN4978chisel ISO A, ISO3, DIN 4978

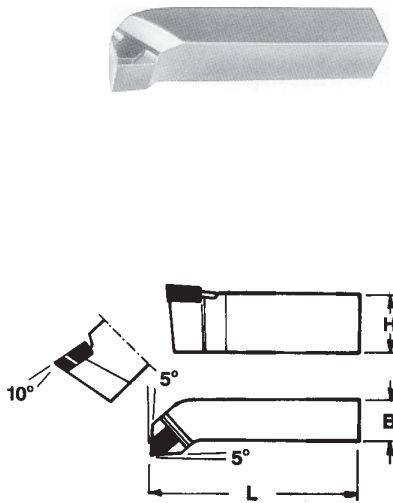

Schafthöhe hauteur tige shank height mm	Schaftbreite largeur tige shank width mm	Gesamtlänge long. totale total length mm	Ausführ./exec. rechts R links L à droite R gauche L right R left L	Hartmetallsorte nuance métal dur carbide grade K10 P25 P40	Best.Nr. no.cde. order no.	Preis prix price CHF	
10	10	90	R	K10	371703. 1010	8.20	
			R	P25	371703. 1020	8.20	
			R	P40	371703. 1040	8.20	
			L	K10	371703. 1015	8.20	
			L	P25	371703. 1025	8.20	
12	12	100	R	K10	371703. 1210	10.40	
			R	P25	371703. 1220	10.40	
			R	P40	371703. 1240	10.40	
			L	K10	371703. 1215	10.40	
			L	P25	371703. 1225	10.40	
16	16	100	R	K10	371703. 1610	11.70	
			R	P25	371703. 1620	11.70	
			R	P40	371703. 1640	11.70	
			L	K10	371703. 1615	11.70	
			L	P25	371703. 1625	11.70	
20	20	125	R	K10	371703. 2010	13.30	
			R	P25	371703. 2020	13.30	
			R	P40	371703. 2040	13.30	
			L	K10	371703. 2015	13.30	
			L	P25	371703. 2025	13.30	
25	25	140	R	K10	371703. 2510	14.80	
			R	P25	371703. 2520	14.80	
			R	P40	371703. 2540	14.80	
			L	K10	371703. 2515	14.80	
			L	P25	371703. 2525	14.80	
32	32	170	R	K10	371703. 3210	39.80	
			R	P25	371703. 3220	39.80	
			R	P40	371703. 3240	39.80	
			L	K10	371703. 3215	39.80	
			L	P25	371703. 3225	39.80	
40	40	200	R	K10	371703. 4010	70.55	
			R	P25	371703. 4020	70.55	
			R	P40	371703. 4040	70.55	
			L	K10	371703. 4015	70.55	
			L	P25	371703. 4025	70.55	
3.71703RL29					P40	371703. 4045	70.55

371704..

Kopfstähle HM- Burins pelle à mise en Wide turning chisel in bestückt ISO4 DIN 4976 carbure ISO 4 DIN 4976 carbide ISO4 DIN 4976

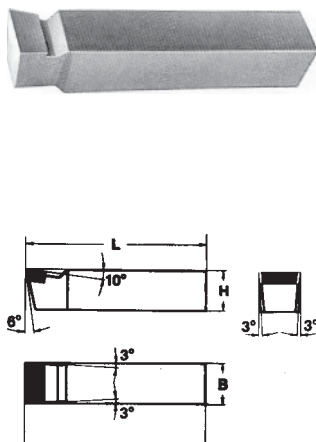

Schafthöhe hauteur tige shank height mm	Schaftbreite largeur tige shank width mm	Gesamtlänge long. totale total length mm	Hartmetallsorte nuance métal dur carbide grade K10 P25 P40	Best.Nr. no.cde. order no.	Preis prix price CHF
10	10	90	K10	371704. 101.	8.40
			P25	371704. 102.	8.40
			P40	371704. 104.	13.00
12	12	100	K10	371704. 121	10.90
			P25	371704. 122	10.90
			P40	371704. 124	12.10
16	16	110	K10	371704. 161	13.00
			P25	371704. 162	13.00
			P40	371704. 164	14.40
20	20	125	K10	371704. 201	17.70
			P25	371704. 202	17.70
			P40	371704. 204	19.50
25	25	140	K10	371704. 251	30.70
			P25	371704. 252	30.70
			P40	371704. 254	33.80
32	20	170	K10	371704. 321	24.00
			P25	371704. 322	24.00
			P40	371704. 324	26.50
40	25	200	K10	371704. 401	38.90
			P25	371704. 402	38.90
			P40	371704. 404	42.90
3.7170421					

Eckdrehstuhl HM-be- Burins à défoncer à mi- front turning chisel
 stückt ISO5 DIN 4977 se en car. ISO5,DIN 4977 carb. ISO5 DIN 4977

371705..

Schafthöhe hauteur tige shank height mm	Schaftbreite largeur tige shank width mm	Gesamtlänge long. totale total length mm	Ausführ./ exec. rechts R links L à droite R gauche L right R left L	Hartmetallsorte nuance métal dur carbide grade K10 P25 P40	Best.Nr. no.cde. order no.	Preis prix price CHF
10	10	90	R	K10	371705. 1010	8.70
			R	P25	371705. 1020	8.70
			R	P40	371705. 1040	9.70
			L	K10	371705. 1015	8.70
			L	P25	371702. 1025	8.70
			L	P40	371705. 1045	9.70
12	12	100	R	K10	371705. 1210	10.00
			R	P25	371705. 1220	10.00
			R	P40	371705. 1240	11.10
			L	K10	371705. 1215	10.00
			L	P25	371705. 1225	10.00
			L	P40	371705. 1245	11.10
16	16	100	R	K10	371705. 1610	10.90
			R	P25	371705. 1620	10.19
			R	P40	371705. 1640	12.10
			L	K10	371705. 1615	10.90
			L	P25	371705. 1625	10.90
			L	P40	371705. 1645	12.10
20	20	125	R	K10	371705. 2010	14.00
			R	P25	371705. 2020	14.00
			R	P40	371705. 2040	15.40
			L	K10	371705. 2015	14.00
			L	P25	371705. 2025	14.00
			L	P40	371705. 2045	15.40
25	25	140	R	K10	371705. 2510	21.60
			R	P25	371705. 2520	21.60
			R	P40	371705. 2540	23.80
			L	K10	371705. 2515	21.60
			L	P25	371705. 2525	21.60
			L	P40	371705. 2545	23.80
32	32	170	R	K10	371705. 3210	32.90
			R	P25	371705. 3220	32.90
			R	P40	371705. 3240	36.30
			L	K10	371705. 3215	32.90
			L	P25	371705. 3225	32.90
			L	P40	371705. 3245	36.30
40	40	200	R	K10	371705. 4010	67.90
			R	P25	371705. 4020	67.90
			R	P40	371705. 4040	74.80
			L	K10	371705. 4015	67.90
			L	P25	371705. 4025	67.90
			L	P40	371705. 4045	74.80

3.71705RL210

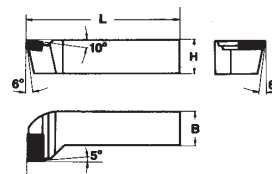
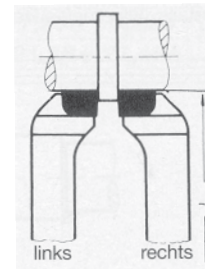

Eckdrehstuhl HM-be- Burins latéraux à mise Side turning chisel in
 stückt ISO 06, DIN 4980 en car. ISO 06, DIN 4980 carb. ISO 06, DIN 4980

371706..

Schafthöhe hauteur tige shank height mm	Schaftbreite largeur tige shank width mm	Gesamtlänge long. totale total length mm	Ausführ./ exec. rechts R links L à droite R gauche L right R left L	Hartmetallsorte nuance métal dur carbide grade K10 P25 P40	Best.Nr. no.cde. order no.	Preis prix price CHF
10	10	90	R	K10	371706. 1010	7.70
			R	P25	371706. 1020	7.70
			R	P40	371706. 1040	8.60
			L	K10	371706. 1015	7.70
			L	P25	371706. 1025	7.70
			L	P40	371706. 1045	8.60
12	12	100	R	K10	371706. 1210	8.80
			R	P25	371706. 1220	8.80
			R	P40	371706. 1240	9.80
			L	K10	371706. 1215	8.80
			L	P25	371706. 1225	8.80
			L	P40	371706. 1245	9.80
16	16	100	R	K10	371706. 1610	10.80
			R	P25	371706. 1620	10.80
			R	P40	371706. 1640	11.90
			L	K10	371706. 1615	10.80
			L	P25	371706. 1625	10.80
			L	P40	371706. 1645	11.90
20	20	125	R	K10	371706. 2010	13.50
			R	P25	371706. 2020	13.50
			R	P40	371706. 2040	14.90
			L	K10	371706. 2015	13.50
			L	P25	371706. 2025	13.50
			L	P40	371706. 2045	14.90
25	25	140	R	K10	371706. 2510	20.50
			R	P25	371706. 2520	20.50
			R	P40	371706. 2540	22.60
			L	K10	371706. 2515	20.50
			L	P25	371706. 2525	20.50
			L	P40	371706. 2545	22.60
32	32	170	R	K10	371706. 3210	31.10
			R	P25	371706. 3220	31.10
			R	P40	371706. 3240	34.30
			L	K10	371706. 3215	31.10
			L	P25	371706. 3225	31.00
			L	P40	371706. 3245	34.30
40	40	200	R	K10	371706. 4010	58.10
			R	P25	371706. 4020	58.10
			R	P40	371706. 4040	64.00
			L	K10	371706. 4015	58.10
			L	P25	371706. 4025	58.10
			L	P40	371706. 4045	64.00

3.71706RL29

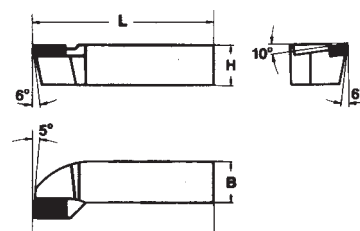
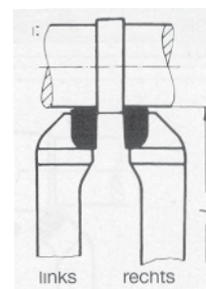

371707..

Abstechstähle HM-be- Burins à tronçonner en Cut-of turning chisel
stückt ISO 7, DIN 4981. carbure ISO 7, DIN 4981 carb. ISO 7, DIN 4981.

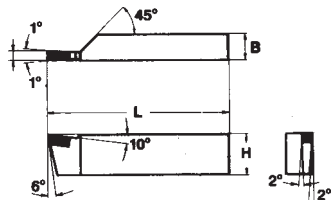
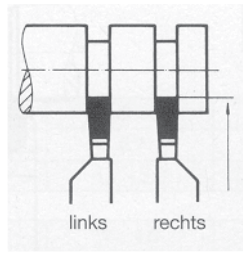

Schafthöhe	Schaftbreite	Gesamtlänge	Schneidenbreite	Ausführ./exec.		Hartmetallsorte			Best.Nr.	Preis
hauteur tige	largeur tige	long. totale	largeur lame	rechts R	links L	nuance métal dur			no.cde.	prix
shank height	shank width	total length	width chisel	à droite R	gauche L	carbide grade			order no.	price
mm	mm	mm	mm	right R	left L	K10	P25	P40		CHF
12	8	100	3	R		K10			371707. 1210	8,50
				R			P25		371707. 1220	8,50
				R			P40		371707. 1240	9,30
					L	K10			371707. 1215	8,50
					L		P25		371707. 1225	8,50
					L		P40	371707. 1245	9,30	
16	10	110	4	R		K10			371707. 1610	9,20
				R			P25		371707. 1620	9,20
				R			P40		371707. 1640	10,30
					L	K10			371707. 1615	9,20
					L		P25		371707. 1625	9,20
					L		P40	371707. 1645	10,30	
20	12	125	5.5	R		K10			371707. 2010	11,10
				R			P25		371707. 2020	11,10
				R			P40		371707. 2040	12,30
					L	K10			371707. 2015	11,10
					L		P25		371707. 2025	11,10
					L		P40	371707. 2045	12,30	
25	16	140	6.5	R		K10			371707. 2510	15,90
				R			P25		371707. 2520	15,90
				R			P40		371707. 2540	17,50
					L	K10			371707. 2515	15,90
					L		P25		371707. 2525	15,90
					L		P40	371707. 2545	17,50	
32	20	170	8.5	R		K10			371707. 3210	22,20
				R			P25		371707. 3220	22,20
				R			P40		371707. 3240	24,40
					L	K10			371707. 3215	22,20
					L		P25		371707. 3225	22,20
					L		P40	371707. 3245	24,40	
40	25	200	9.5	R		K10			371707. 4010	37,50
				R			P25		371707. 4020	37,50
				R			P40		371707. 4040	41,50
					L	K10			371707. 4015	37,50
					L		P25		371707. 4025	37,50
					L		P40	371707. 4045	41,50	
50	32	240	10.5	R		K10			371707. 5010	79,00
				R			P25		371707. 5020	79,00
				R			P40		371707. 5040	87,00
					L	K10			371707. 5015	79,00
					L		P25		371707. 5025	79,00
					L		P40	371707. 5045	87,00	

3.71707RL217

Bestell-Beispiel / Exemple d' une commande/ order example: 71707.. R, 20x10x125, P25 = 371707.2020

371708..

Innenschruppstahl HM- Burins à aléser à mise Internal turning roug-
best.zylindrisch.Schaft en carbure, tige cylin- hing chisel, cylindrical
ISO 08, DIN 4973 drique ISO 08, DIN 4973 shank ISO 08, DIN 4973

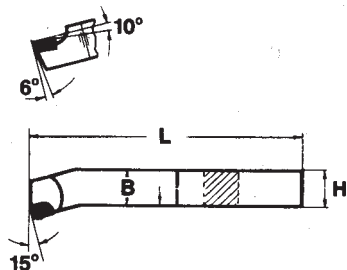
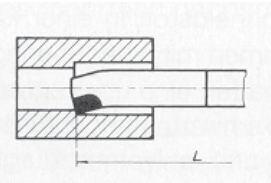

Schafthöhe	Schaftbreite	Gesamtlänge	Hartmetallsorte			Best.Nr.	Preis	
hauteur tige	largeur tige	long. totale	nuance métal dur			no.cde.	prix	
shank height	shank width	total length	carbide grade			order no.	price	
mm	mm	mm	K10	P25	P40		CHF	
10	10	150	K10			371708. 101	9,20	
					P25		371708. 102	9,20
					P40		371708. 104	10,30
12	12	180	K10			371708. 121	11,50	
					P25		371708. 122	11,50
					P40		371708. 124	12,60
16	16	210	K10			371708. 161	14,00	
					P25		371708. 162	14,00
					P40		371708. 164	15,50
20	20	250	K10			371708. 201	17,00	
					P25		371708. 202	17,00
					P40		371708. 204	18,80
25	25	300	K10			371708. 251	26,20	
					P25		371708. 252	26,20
					P40		371708. 254	28,80
32	32	355	K10			371708. 321	39,20	
					P25		371708. 322	39,20
					P40		371708. 324	43,30
40	40	200	K10			371708. 401	83,00	
					P25		371708. 402	83,00
					P40		371708. 404	83,00

371.708.217

Inneneckstahl HM-best. Zyl.Sch., ISO 9, DIN 4974

Lieferbare Hartmetallsorten: K10 für Gussbearbeitung, P25 für Stahl-u.Stahllegierungen, P40 für rostfreie Stähle.

Burin à aléser & à dres., tige cyl., ISO 09, DIN 4974

Nuances de métal dur livrables: K10 pour fonte, P25 p. acier-et alliages d'acier, P40 pour aciers inoxydables.

Internal corner turn. chisel carb. ISO 9, DIN 4974

Available carbide grades: K10 for cast iron & non ferrous metals, P25 for steel & alloyed steel, P40 for stainless steel.

371709..

Schafthöhe hauteur tige shank height	Schaftbreite largeur tige shank width	Gesamtlänge long. totale total length	Hartmetallsorte nuance métal dur carbide grade	Best.Nr. no.cde. order no.	Preis prix price
mm	mm	mm	K10 P25 P40		CHF
10	10	150	K10	371709. 101	8.30
			P25	371709. 102	8.30
			P40	371709. 104	9.70
12	12	180	K10	371709. 121	10.80
			P25	371709. 122	10.80
			P40	371709. 124	11.90
16	16	210	K10	371709. 161	13.20
			P25	371709. 162	13.20
			P40	371709. 164	14.60
20	20	250	K10	371709. 201	16.00
			P25	371709. 202	16.00
			P40	371709. 204	17.70
25	25	300	K10	371709. 251	24.70
			P25	371709. 252	24.70
			P40	371709. 254	27.20
32	32	355	K10	371709. 321	37.00
			P25	371709. 322	37.00
			P40	371709. 324	40.80
40	40	200	K10	371709. 401	79.60
			P25	371709. 402	79.60
			P40	371709. 404	79.60

3.7170929

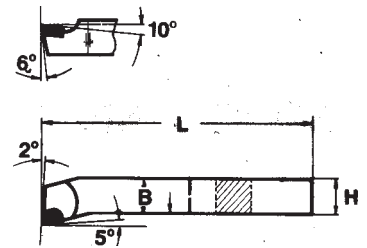

Automatendrehstahl

Lieferbare Hartmetallsorten: K10 für Gussbearbeitung, P25 für Stahl-u.Stahllegierungen, INOX für rostfreie Stähle.

Burin de décol. à tourn. Chisels for automatics

Nuances métal dur livrables: K10 pour fonte, P25 p. acier et alliages d'acier, INOX pour aciers inoxydables.

Available carbide grades: K10 for cast iron & non ferrous metals, P25 for steel & alloyed steel, INOX for stainless steel.

371712..

Schafthöhe hauteur tige shank height	Schaftbreite largeur tige shank width	Gesamtlänge long. totale total length	Ausführ. / exec. rechts R links L à droite R gauche L	Hartmetallsorte nuance métal dur carbide grade	Best.Nr. no.cde. order no.	Preis prix price
mm	mm	mm	right R left L	K10 P25 P40		CHF
4	4	150	R	P25	371712. 0401	19.95
			R	K10	371712. 0402	14.20
			L	P25	371712. 0451	14.20
5	5	150	R	P25	371712. 0501	8.20
			R	K10	371712. 0502	8.20
			L	P25	371712. 0551	8.20
6	6	150	R	P25	371712. 0601	8.20
			R	K10	371712. 0602	8.20
			R	INOX	371712. 0608	9.05
7	7	150	R	P25	371712. 0651	8.20
			R	K10	371712. 0652	8.20
			L	P25	371712. 0701	9.05
8	8	150	R	P25	371712. 0702	9.05
			R	K10	371712. 0751	9.05
			R	INOX	371712. 0752	9.05
9	9	150	R	P25	371712. 0758	9.05
			R	K10	371712. 0801	9.45
			R	INOX	371712. 0802	9.45
10	10	150	R	P25	371712. 0808	9.45
			R	K10	371712. 0851	9.45
			R	INOX	371712. 0852	9.45
12	12	150	R	P25	371712. 0858	9.45
			R	K10	371712. 0951	14.00*
			R	INOX	371712. 0952	14.00*
14	14	150	R	P25	371712. 1001	10.20
			R	K10	371712. 1002	10.20
			R	INOX	371712. 1008	10.20
16	16	150	R	P25	371712. 1051	10.20
			R	K10	371712. 1052	10.20
			R	P40	371712. 1054	15.05
12	12	150	R	P25	371712. 1058	10.20
			R	K10	371712. 1201	11.25
			R	INOX	371712. 1202	11.25
14	14	150	R	P25	371712. 1251	11.25
			R	K10	371712. 1252	11.25
			R	INOX	371712. 1258	11.25
16	16	150	R	P25	371712. 1401	12.50
			R	K10	371712. 1402	12.50
			R	INOX	371712. 1451	12.50
16	16	150	R	P25	371712. 1452	12.50
			R	K10	371712. 1601	16.15
			R	INOX	371712. 1602	16.15
16	16	150	R	P25	371712. 1651	16.15
			R	K10	371712. 1652	16.15

3.71712RL29

*solange Vorrat/jusqu'à l'épuisement du stock

